

# CLUTCH PUMP INSTALLATION INSTRUCTIONS

- **WARNING** — This clutch pump is for a 12 volt D.C. circuit.

Immediately upon unpacking the clutch pump, check for shipping damage by spinning the clutch by hand.

- This package should contain the following:

1 - Clutch Pump	2 - Star Washers	2 - Butt Splice
1 - 12 Foot Length of Wire	1 - Fork Connector	1 - Switch Mounting Bracket with Screws, Lockwashers & Nuts
1 - Rocker Switch & Light	2 - Bullet Connectors	1 - In-line Fuse
2 - Ring Terminals	3 - Spade Connectors	

- **Fanbelt Clutch Pump Installation**

- **Mounting Bracket for Clutch Pump**

Muncie has clutch pump engine mounting kits for selected engines. Contact Muncie for further information. These kits work on new style engines with serpentine belt drive.

- **Fanbelt Clutch Pump Drive (Standard)**

Driven directly from crankshaft pulley with two (2) "A" belts.

A 180° wrap on the drive and driven pulleys is desirable.

The clutch pump sheaves must be exactly aligned with the crankshaft sheaves.

The clutch pump should be located as close to the crankshaft as possible.

- **Fanbelt Clutch Pump Drive (Serpentine)**

Uses 6 groove class K-poly "V" belt.

Taps into factory belt drive.

No mounting bracket or kits available.

Maximum horsepower draw is 11HP.

Clutch pump sheave must be aligned with the other pulleys.

- **Fanbelt Tensioning**

A moveable mounting base as opposed to idler pulleys is preferred for tensioning.

A Dodge belt tension tester #109082 or its equivalent should be used to determine the proper belt tension.

It should take a force of 3.5 to 5 lbs. to deflect the belt 3/16" per foot of span. **Improper tensioning can cause premature pump failure and void warranty.**

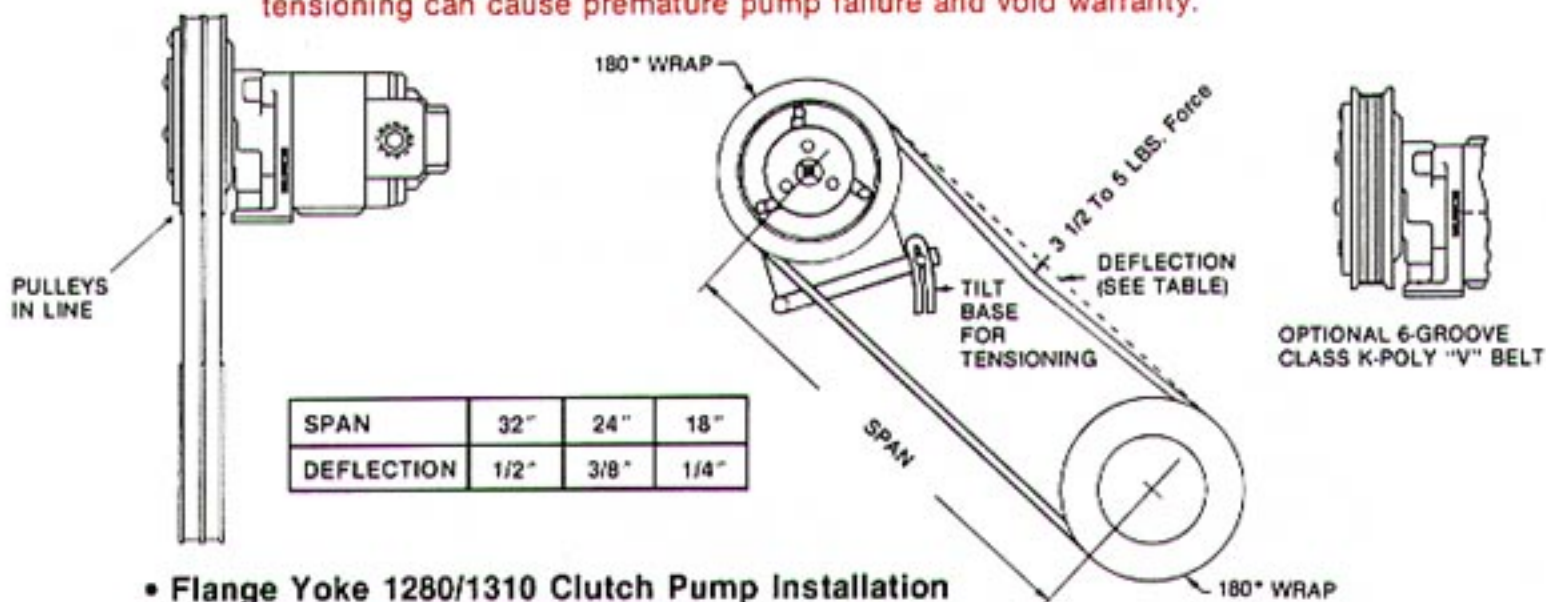

- **Flange Yoke 1280/1310 Clutch Pump Installation**

Use a 1280/1310 series tubular drive line assembly.

True joint angle of drive line must be greater than three degrees and less than seven degrees.

The clutch pump shaft and the engine crankshaft must be parallel to each other.

The flange yokes on the drive line assembly must be in phase.

**If the above parameters are not complied with, a premature failure may occur and void warranty.**

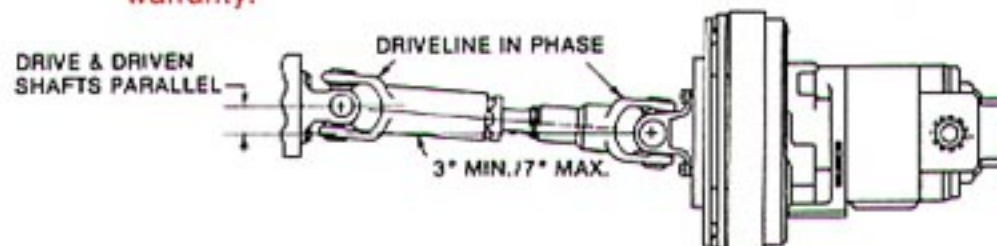

## • Rocker Switch & Light Installation

This switch is usually mounted in the dashboard frame at the base of the dash. Using the mounting bracket as a template, drill two (2) 7/32" dia. holes in the frame. Use the two (2) capscrews, lockwashers and nuts to attach bracket to frame.

## • Wiring Installation

Four (4) separate lengths of wire are needed for installation.

1. Rocker switch to accessory fuse panel.
2. Rocker switch to ground.
3. Rocker switch to coil.
4. Coil to ground (frame).

Determine the four (4) required lengths of wire and cut appropriately.

Crimp a spade terminal onto the appropriate wires and connect to the correct brass male spade on the rocker switch (see diagram).

Attach the other end of the ground wire to the predetermined ground point with a ring terminal and star washer.

Attach the other end of the fuse wire to a terminal in accessory fuse panel.

Join the clutch wire to either coil wire with a butt splice.

Join the other clutch wire with the final length of wire.

Attach coil ground wire to frame with a ring terminal and star washer. Do not ground to pump or pump bracket.

**NOTE:** Muncie burnishes the clutch plate of all fan belt clutch pumps before shipment. However, extended shelf storage may cause deterioration of the plate surface, and reburnishing may be necessary upon installation. All driveshaft driven (FY) clutch pumps should be burnished as described below.

### • Clutch Pump Start Up and Burnishing

1. Back relief valve down to 500 PSI and cycle rocker switch 25 times with truck engine at 1000 RPM.
2. Repeat step #1 in 500 PSI higher increments until you reach the desired pressure relief setting.
3. If the armature leaf spring and disc do not snap firmly against the friction surface, check voltage at clutch lead.
4. Less than 11.5 volts will result in clutch slippage and consequent damage to the clutch.

- Clutch may need to be reburnished if placed back into service after extended non-usage (over 30 days).

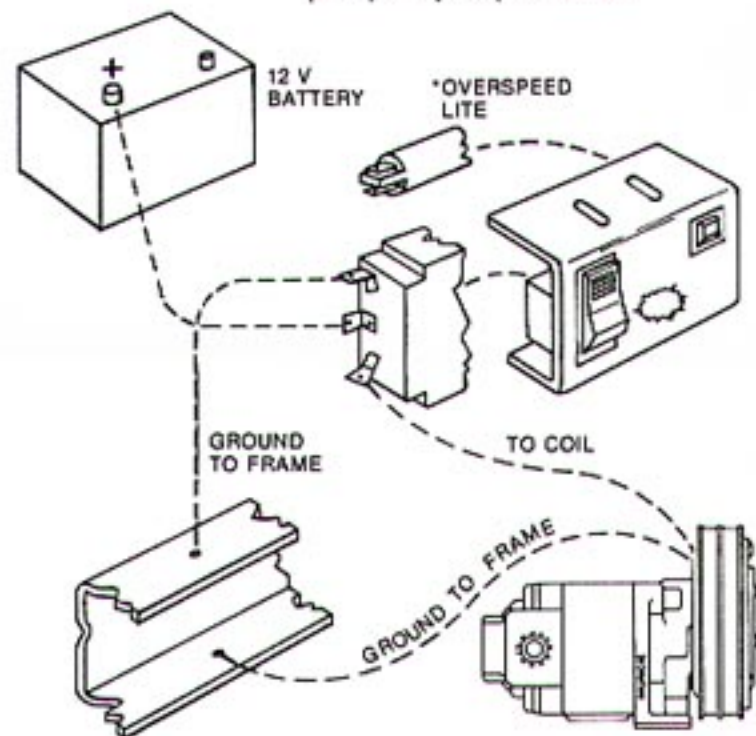

\*Overspeed Lite to be used with Muncie EOS-110 Overspeed Switch

**RESERVOIR PLACEMENT:** The level of the oil in the reservoir should be no lower than the inlet port of the pump.

**SUITABLE FLUIDS:** SAE 10W A.W.R. & O. Hydraulic Oil with Anti-Wear, Rust and Oxidation Additives. Systems should not exceed a maximum of 180° F . . . SUCTION LIFT not to exceed 5 in. Hg at operating speed.

**FILTRATION:** Return line filter in the 10 micron range is acceptable. Suction filters and strainers are not approved . . . if the system is cleaned properly, they are unnecessary. Filter should be changed at each second engine filter change.

**HOSE SIZES:** All hoses are to be sized so that the flow velocity, rated in feet per second (FPS), does not exceed 15 FPS in the pressure line, 8 FPS in the return line and 4 FPS in the inlet line.

# TROUBLE SHOOTING GUIDE FOR HYDRAULICS

Hydraulic analysis and proper repair require the use of a vacuum gauge and pressure gauge for testing.

Electrical analysis requires using a volt meter for testing.

Possible Pump Trouble	Cause	Cure
<b>Aeration/Cavitation: noisy pump</b> Use vacuum gauge to isolate problem	Low oil supply. Heavy oil / cold oil / wrong oil. Dirty suction strainer. Suction line too small. Restriction in suction line.	Fill to proper level. Change to proper oil. Clean and replace. Increase size. Remove and replace.
<b>Pump takes too long to respond or fails to respond</b>	Low oil supply. Insufficient relief valve pressure. Pump worn or damaged.	Fill to proper level. Use gauge to reset pressure. Repair or replace.
<b>Oil Heating Up</b>	Contamination in relief valve. Oil too light. Dirty oil. Oil level too low. Reservoir capacity too small. Insufficient relief valve pressure or pressure too high. Pump slippage	Remove. Drain and refill with proper oil. Drain, flush, refill with clean oil. Fill to proper level. Install oil cooler. Use gauge to reset pressure.  Repair or replace.
<b>Oil Foaming</b>	Air leaking into suction line from tank to pump. Wrong kind of oil. Oil level too low. Improper tank or reservoir baffle. Return line above oil level.	Tighten all connections.  Drain & refill w/non-foaming oil. Fill to proper level. Baffle correctly. Install below oil level.
<b>Actuator Slips</b>	Contamination damages control valve and allows check valve to leak. Cylinder or piston packing defective. Valve is cracked. Spool not centering. Incorrect oil. Load check stuck.	Clean out the system.  Repair or replace. Replace. Clean contaminants from valve or replace. Replace with correct oil. Open.
<b>Clutch Does Not Engage</b>	Bad electrical connection. Blown fuse. Switch won't activate. Low voltage. Coil bad.	Check wiring, connectors, and source. Replace (9A max) — check for short. Replace switch. Check wiring. Check w/ohmmeter (2.3 ohms) and replace.
<b>Belts Jumping Off</b>	Belts too loose. Belts worn or scratched. Mounting bracket loose. Pulleys misaligned. Drive pulley loose. Diesel vibration/belt slap.	Tighten to specifications. Replace. Tighten or replace bolts. Align properly with straight edge. Tighten. Add back side idler to dampen.
<b>Clutch Slips</b>	Low voltage. Bad ground. Torque overload. Dirt/grease on armature. Armature plate rusted. Pump locked up/damaged.	Check wiring and source. Ground to battery. Reduce flow or pressure. Clean and reburnish. Reburnish. Replace pump.
<b>Clutch Rubs</b>	Pulley bent. Armature plate warped. Coil mounting damaged.	Replace pulley. Replace pulley. Replace coil.